

# TECHNICAL SPECIFICATIONS

## KIDE Industrial Cold Panel



**Member of the following associations:**

- APIP'ÑA** Asociación de Fabricantes de Paneles de Poliuretano Inyectado de España
- ANDIMAT** Asociación Nacional de Fabricantes de Materiales Aislantes
- SNI** Syndicat National de l'Isolation
- ANEFRYC** Asociación Nacional de Empresas de Maquinaria y Equipos para la producción de Frío y Climatización
- AEC** Asociación Española de la Calidad
- EOQ** European Organization for Quality

**Standard EN-14509**  
**Standard EN-ISO-9001**  
**Standard EN-ISO-14001**



Polígono Gardotza s/n, 48710 BERRIATUA, Bizkaia- SPAIN  
Tel: +34 94 603 62 08  
Fax: +34 94 603 62 21  
E-mail: [kide@kide.com](mailto:kide@kide.com)  
<http://www.kide.com>

## 1 Concept

### 1.1 Definition

The prefabricated KIDE panels are made up of an insulating core of rigid polyurethane foam, the 2 surfaces of which receive a cover of electrogalvanized sheet steel. They are lacquered in their standard version.

The panels are joined together to make walls, floors and insulated roofs, thereby forming a cold room, or an air-conditioned enclosure at positive or negative temperatures.

The union between the panels is obtained by a male-female fitting. Optionally by a hook system incorporated on the long sides of the panels.

The cold-rooms or enclosures should be protected by a dry shelter which forms the roof.

The supporting structure of the building is exterior.

The panels don't take part in the building's structure.

When the panels form part of the exterior of the building, KIDE recommend:

- The outside surface material should be 0,6 mm. shaped steel sheet.
- A silicon sealant should be used along panel joints.
- The colour must be white.

In order to avoid problems due to the condensation:

- Those cavities between the ceiling and roof or premises must be ventilated effectively.
- It is recommended to isolate the floors of those cold rooms whose temperature is next to 0 + 5°C, when they go located on premises, etc.

### 1.2 Objective

The objective of this paper is to define the minimum prescriptions for this product and its accessories in terms of conception, manufacture, packaging, assembly and maintenance, taking into account the professional experience of KIDE, the laws and the Standards in force at the moment and the safety demands, durability and comfort expected by the users.

## 2 Description of the Final Product

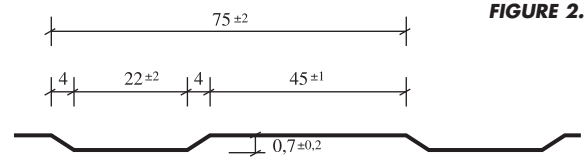
The KIDE panels system is made up of Sandwich type, insulated with injected polyurethane insulation, according to standard EN-14509, and prefabricated in its factory. These basic elements are introduced in the form of panels supplied according to the length in use.

### Panel Composition

- Two faces of galvanized steel, profiled or even, prelacquered.
- A core of rigid polyurethane foam.

**IMPORTANT:** KIDE recommend that shaped steel sheet panels always be used. Should the customer prefer a flat sheet finish, 0,6 mm. sheet must be used.

The profiled panels have the following dimensions:



## 3 Technical Specifications of the materials and components used

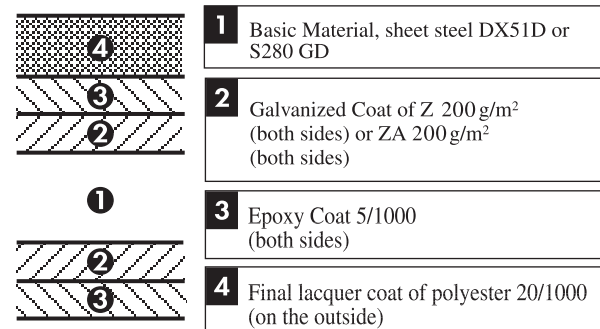
### 3.1 The covering materials:

- They act as resistant members of an element composed against tensile and compression forces.
- They serve as an impermeable protection against water and other agents.

#### 3.1.1 Standard Material

Pre-lacquered sheet steel according to standard EN 10169-1 made from:

**FIGURE 3.1**



- Food quality according to guideline CEE 90/128
- White Colour
- Straightened under tension.
- On demand other types of sheet steel such as Stainless Steel AISI 304 according to EN-10088 and other types of coats such as PLASTISOL (100 m), PVDF (25 m), PLASTICIZED SHEET STEEL (film of 120 microns bonded on the steel sheet) can be supplied.
- The pre-lacquered sheet steel has a plastic coating on the outside face which protects it from scratchings and other mishaps that can take place whilst being handled.

#### 3.1.2 Manufacturing Tolerance

- On thickness of materials used according to Standard EN 10143.
- On dimensional tolerances for sandwich panels according to Standard EN 14509 (Table 3.1)

TABLE 3.1

DIMENSION	TOLERANCE (maximum permissible)
Thickness of the panel	D ≤ 100 mm ± 2 mm D > 100 mm ± 2 %
Deviation from flatness (according to the length of measurement L)	For L = 200 mm – Deviation from flatness 0,6 mm For L = 400 mm – Deviation from flatness 1,0 mm For L > 700 mm – Deviation from flatness 1,5 mm
Length of the panel	L ≤ 3 m ± 5 mm L > 3 m ± 10 mm
Cover width of the panel	W ± 2 mm
Deviation from squareness	0,006 x w (nominal cover width)
Deviation from straightness (on length)	1 mm per metre, maximum 5 mm
Bowing (curvature on length)	2 mm per metre, maximum 10 mm

### 3.2 Insulation

#### 3.2.1 Basic components

Rigid polyurethane foam obtained by chemical reaction between:

- Polyol
- Isocyanate
- Foamig agent
- Catalysts

#### 3.2.2 Specific characteristics

- Insulator of closed cells.
- Average Density 40 Kg/m<sup>3</sup> (tolerance + 3 – 0 Kg/m<sup>3</sup>)
- Thermal Conductivity ( $\lambda = 0,023 \text{ W/m}^\circ\text{C}$ )
- Average Thermal Transmission Coefficient "U" in relation to panel thickness.

THICKNESS in mm.	60	75	100	120	150	180	200
U (W/m <sup>2</sup> °C)	0,38	0,31	0,23	0,19	0,15	0,13	0,12

#### 3.2.3 Reaction to fire

The panel can be classified by their reaction to fire.

- Panel Bs2dO (according to standard EN-13501-1).

#### 3.2.4 Acoustic Insulance

KIDE's acoustic insulance of polyurethane pannels is:  
Rw = 24 (-1; -2) dB.

### 3.3 Various Accessories

- Extruded profiles in aluminium and in PVC.
- Stainless steel hook.
- Silicone Mastic.
- Polyurethane Mastic.
- Polyurethane foam reticulated with closed cells.
- Butyl Mastic.

## 4 Elements

### 4.1 Panels

- The useful width of the panels: 1180 mm.
- The thickness of the panels will vary from 60 mm. to 200 mm.
- The length of the panels will be to a maximum of 12 m.
- The long edges of the panels are male-female section.

The vertical panels could have:

- Top edge:
  - Flat in positive Cold Room
  - Raised in L-shape, depending on the thickness of the roof panel in negative Cold Room
- Bottom edge: - Flat

The roof panels will have the two edges flat.

Both the vertical as well as the roof panels can have metallic insertions if they are fastened to the structure by means of clamps.

### 4.2 Accessories

#### 4.2.1 Fastening Insertions

They are made of sheet steel of 3 mm. thickness.  
(Figure 4.2)

#### 4.2.2 Fastening of the vertical panels

This is done by means of clamps fastened onto the insertions.  
(Figure 4.3). Use 2 screws of size DIN 7504-K Ø 6,3x32

#### 4.2.3 Fastening of the roof panels

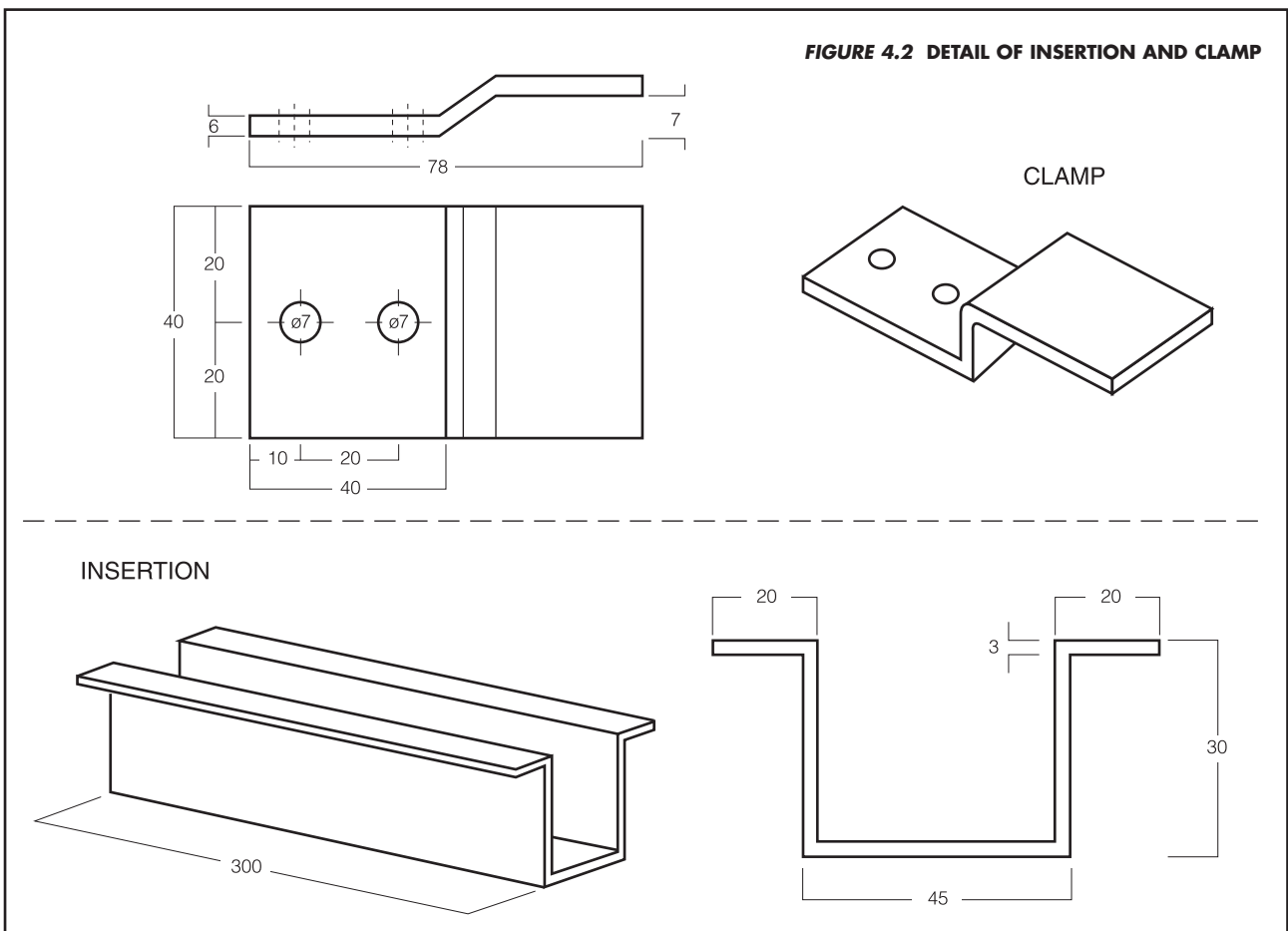
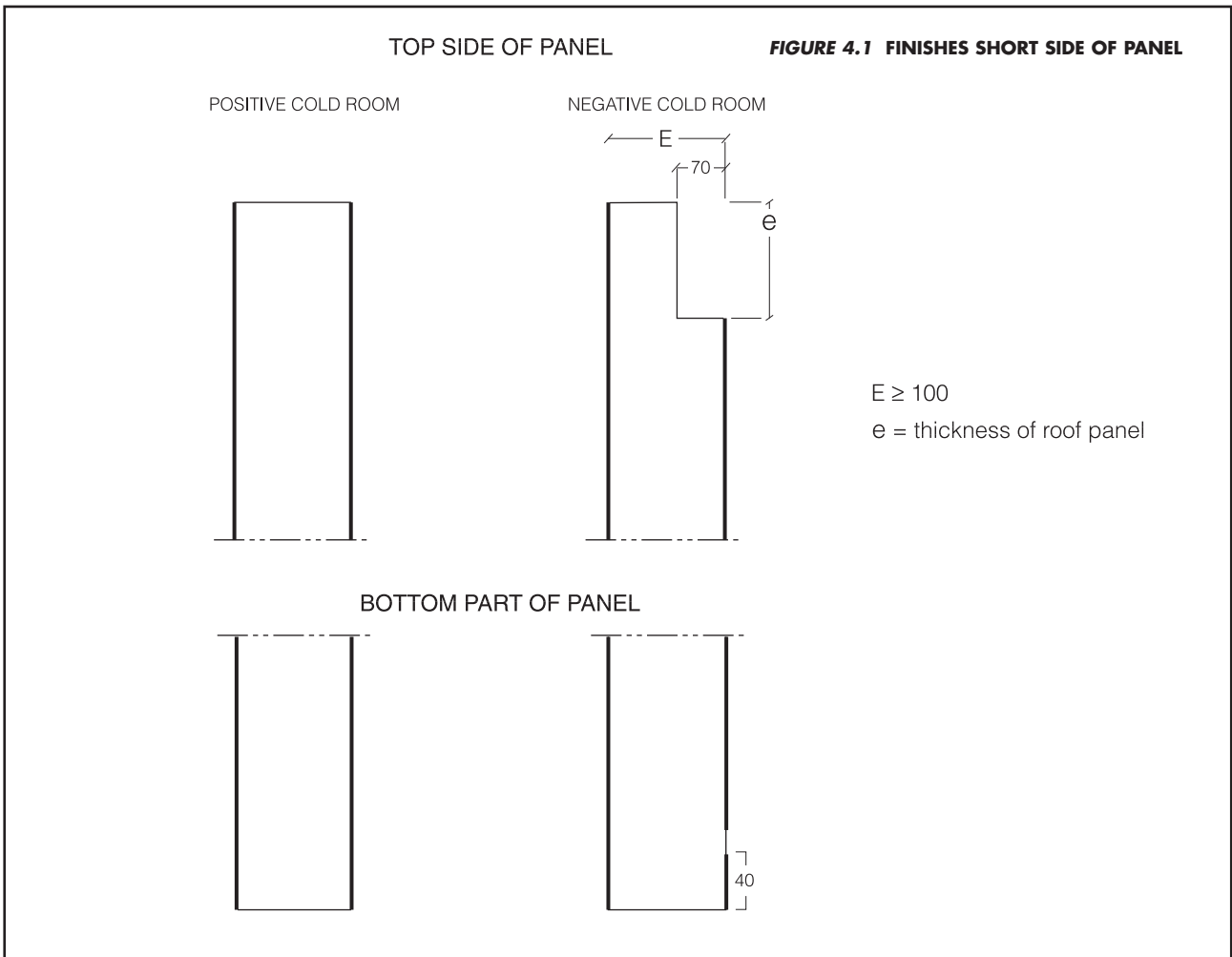
This is done by means of T-profiles made from extruded aluminium or from pulltruded polyester.  
(Figure 4.4)

Occasionally the clamps, flanges or insulated washers can be used.

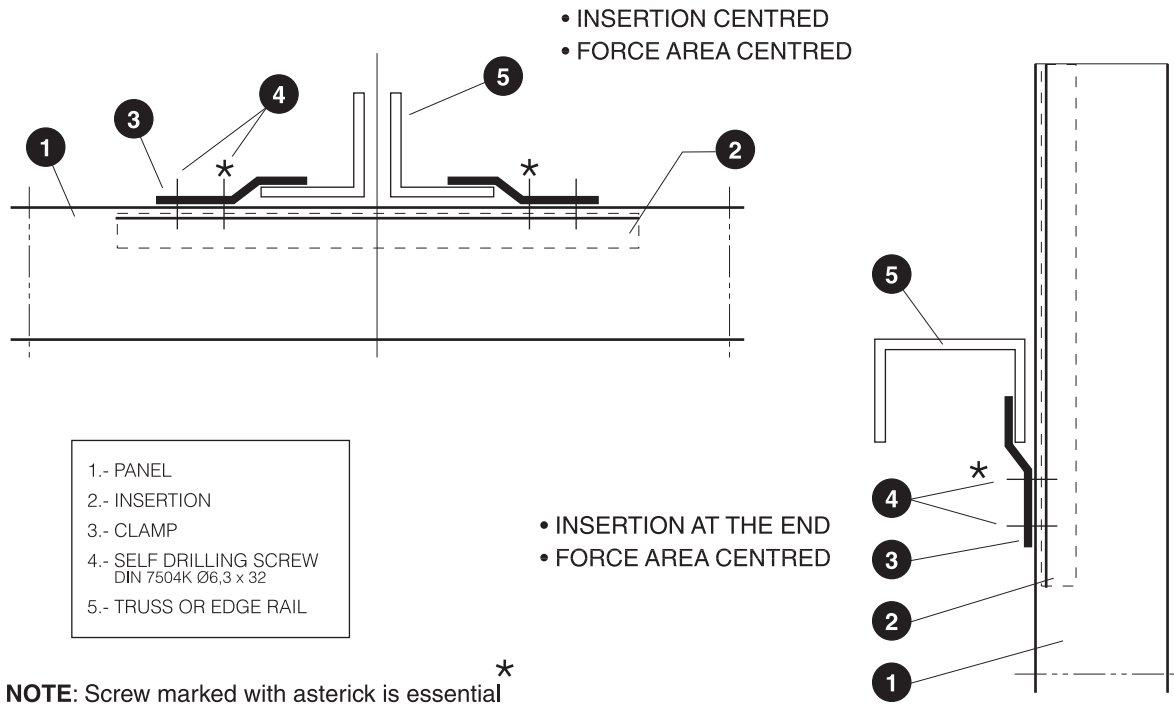
#### 4.2.4 Joining and finishing profiles

These are made from the sheet steel of the same type as used in panel walls. The long sides have a 180° bend towards the inside.

These elements will have a maximum of 3 m. in length.



**FIGURE 4.3 FASTENING OF PANEL WITH INSERTIONS AND CLAMPS**



## 5 Manufacture and control

KIDE is in possession of a COMPANY REGISTER CERTIFICATE certified by AENOR (member of IGS) under the register ER-0110-1993, having a system for QUALITY ASSURANCE according to standard EN-ISO-9001 and the register GA-1997/0017 having an ENVIRONMENTAL MANAGEMENT CERTIFICATE according to standard EN-ISO-14001, whose scope is the design, development and production of commercial refrigeration equipment and insulating sandwich panels of polyurethane, polystyrene and mineral wool, and doors for cold and air-conditioned rooms and other enclosed facilities.

The KIDE panels are manufactured in its own industrial factory at BERRIATUA (Bizcaia), Spain, taking into account the Standards and Systems:

ERAIKIZ	Management System for the Prevention of Risks at work.
EN-ISO-9001	Quality Control Systems. Model for the quality assurance in production, installation and associated services.
EN-ISO-14001	Management System for the Environment.
EN-14509	Self-supporting double skin metal face insulating panels.

### 5.1 Process and Product Control

- Control of the productive process by the quality control department by following the procedures and instructions established for the manufacture of the panel.
- Product control by the quality control department
  - Panel dimensions
  - Panel finish
  - Sheet steel thickness
  - Tensile and compressive strength
  - Tensile and compressive modulus
  - Shear strength
  - Dimensional stability at  $-20^{\circ}\text{C}$

### 5.2 Annual Control of the panel characteristics

These are carried out in well-known laboratories where it is verified if the panel complies with the standard EN-14509.

- Density
- Tensile strength
- Shear strength
- Compression strength
- Tensile modulus
- Compression modulus
- Shear modulus
- Fire reaction
- Coefficient of conductivity ( $\lambda$ )
- Panel identification

## 6 Assembly of panels for cold rooms

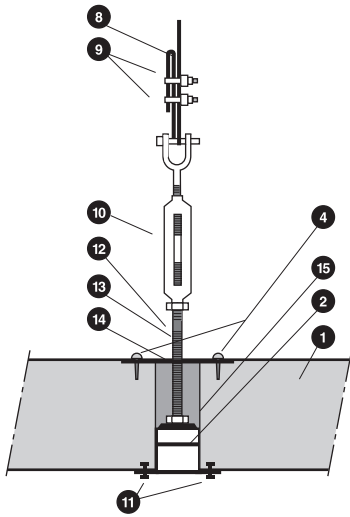
The requirements for standard ISO-14001 (environmental management system), and ERAIKIZ (management system for the prevention of risks at work) will be taken into account.

### 6.1 Assembly Organization

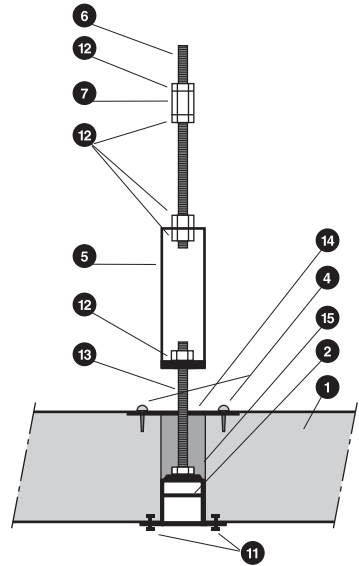
KIDE has its own assembly service and offers the following options:

- Carrying out Assembly itself.
- Allowing Assembly to be carried out by trusted exclusive subcontractors.
- Realization of the study and assembly plans and giving a service of technical assistance on site for its assembly to every company designated by the client.

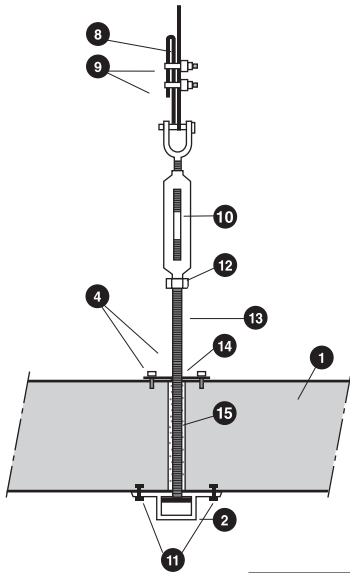
**FIGURE 4.4**  
**FASTENING OF ROOF BY "T" PROFILE**



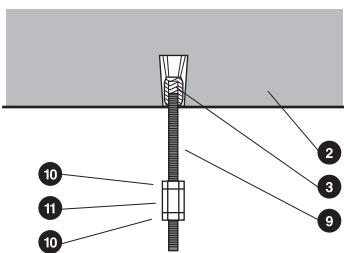
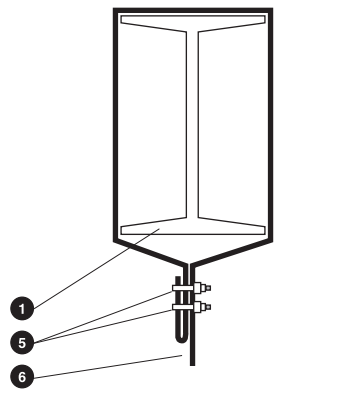
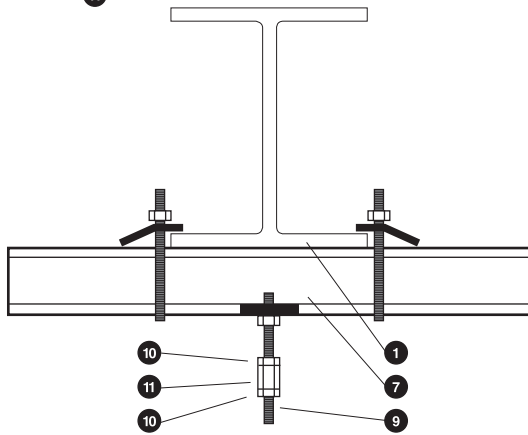
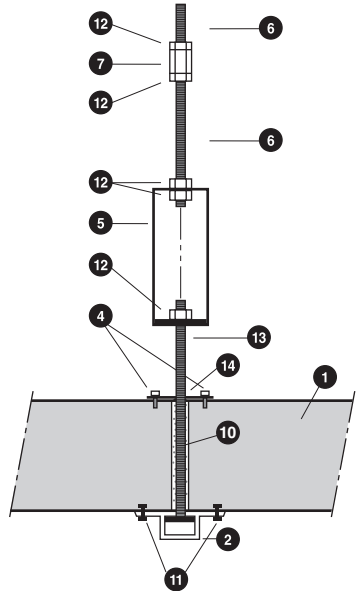
NEGATIVE COLD ROOM



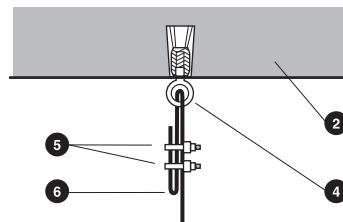
- 1.- PANEL
- 2.- SUSPENDED PROFILED
- 4.- SELF DRILLING SCREW 4,8 x 25
- 5.- SAIZAR TENSOR
- 6.- THREADED STUD M-10
- 7.- LENGTHENING NUT M-10 x 30
- 8.- STEEL CABLE Ø5
- 9.- PRISONER 1/4
- 10.- 3/8 TENSOR WITH YOKE FOR STUD
- 11.- WHITE RIVET 4x15
- 12.- NUT M-10
- 13.- ALUMINIUM "T" FASTENING
- 14.- SEAL COVER
- 15.- POLYURETHANE INJECTION



POSITIVE COLD ROOM



- 1.- STRUCTURE (TOP BEAM)
- 2.- CONCRETE
- 3.- METAL SPIRAL ROD M-10 x 40
- 4.- EYEBOLT CLOSED M-10 x 70
- 5.- PRISONER 1/4
- 6.- STEEL CABLE Ø5
- 7.- RAIL 38/40 + RAIL NUT + 2 FERAGRIP M-8 + SAFETY PLATE
- 9.- THREADED STUD M-10
- 10.- NUT M-10
- 11.- LENGTHENING NUT M-10 x 30



## 6.2 Control of Work carried out

Work Inspectors control the quality of the work carried out by the KIDE assembly service and by the specialized sub-contractors.

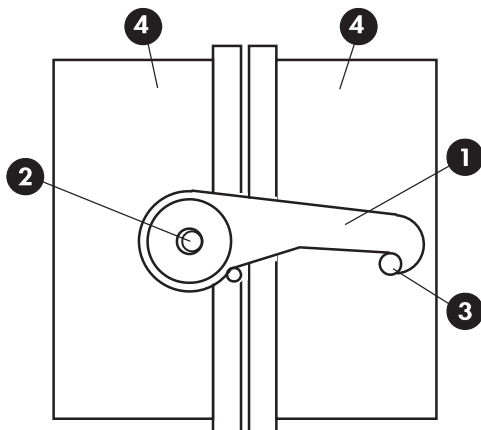
## 6.3 Joining Systems between Panels

### 6.3.1 Joining System for vertical and roof panels

The System is identical for the vertical as well as for the roof panels.

The Joining System will be made pressing of the male-female and approaching one panel against the next one. Optionally, if the panels have hooks (Figure 6.1), the joint will be made by turning an eccentric hook (1) by a square key (2) and hooked to a metallic axle (3). The axle, as well as the hook (made from stainless steel) go into some plastic boxes (4), placed inside the panel.

FIGURE 6.1



Once the panels are hooked, the access hole to the opening-closing hexagon is covered by pressure with a plastic stopper. The hook has two positions: the first one helps to pull and place in position, and the second one to tighten.

These hooks are situated only on the long side of the panel.

When the panels are correctly assembled, the joint between the polyurethane, assure the insulation of the joint. (Figure 6.2)

BREATHABILITY: = "0" at 50 Pa (EN 12114)

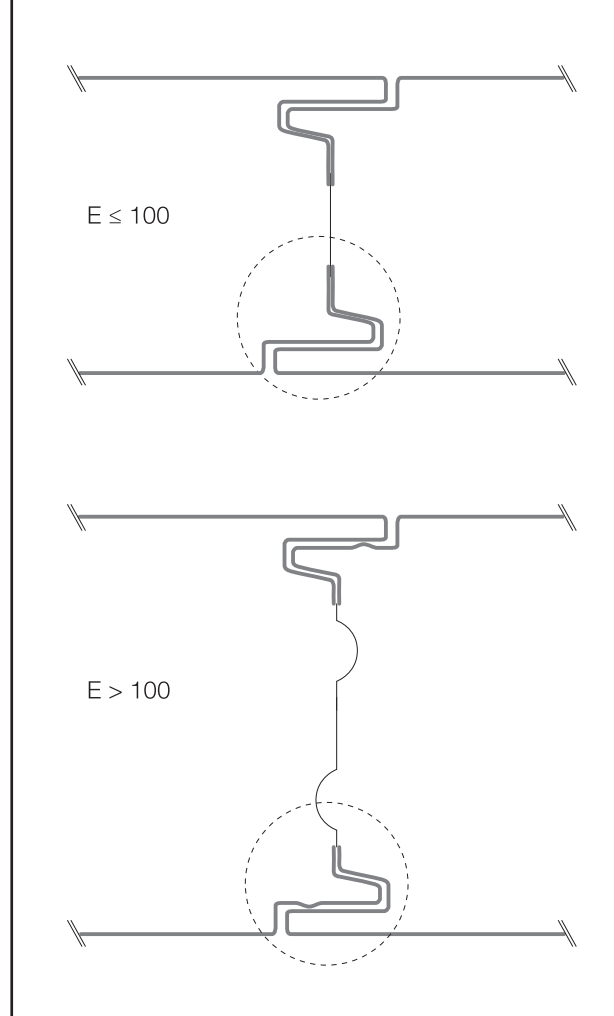
WATERPROOFNESS: "A" at 1200 Pa (EN 12865)

Depending on the use given to the cold room (or when there is a special need, for example, a requirement from the veterinary service), it is possible to apply a silicon seal on site.

The choice will be proposed by the works manager taking into account the type of seal for each case:

- Silicone Seal: Water and airtight
- Butyl Seal: Water vapourtight
- Foam Seal injected in situ: The maintenance of insulation at low temperature (< 0°C) in the cold rooms.

FIGURE 6.2 BETWEEN VERTICAL AND ROOF PANELS



### 6.3.2 Various joints

#### 6.3.2.1 Cold Rooms with positive temperature

- Floor – Wall Assembly (Figure 6.3)
- Wall – Wall Assembly (Figure 6.4)
- Wall – Roof Assembly (Figure 6.5)

#### 6.3.2.2 Cold Rooms with negative temperature

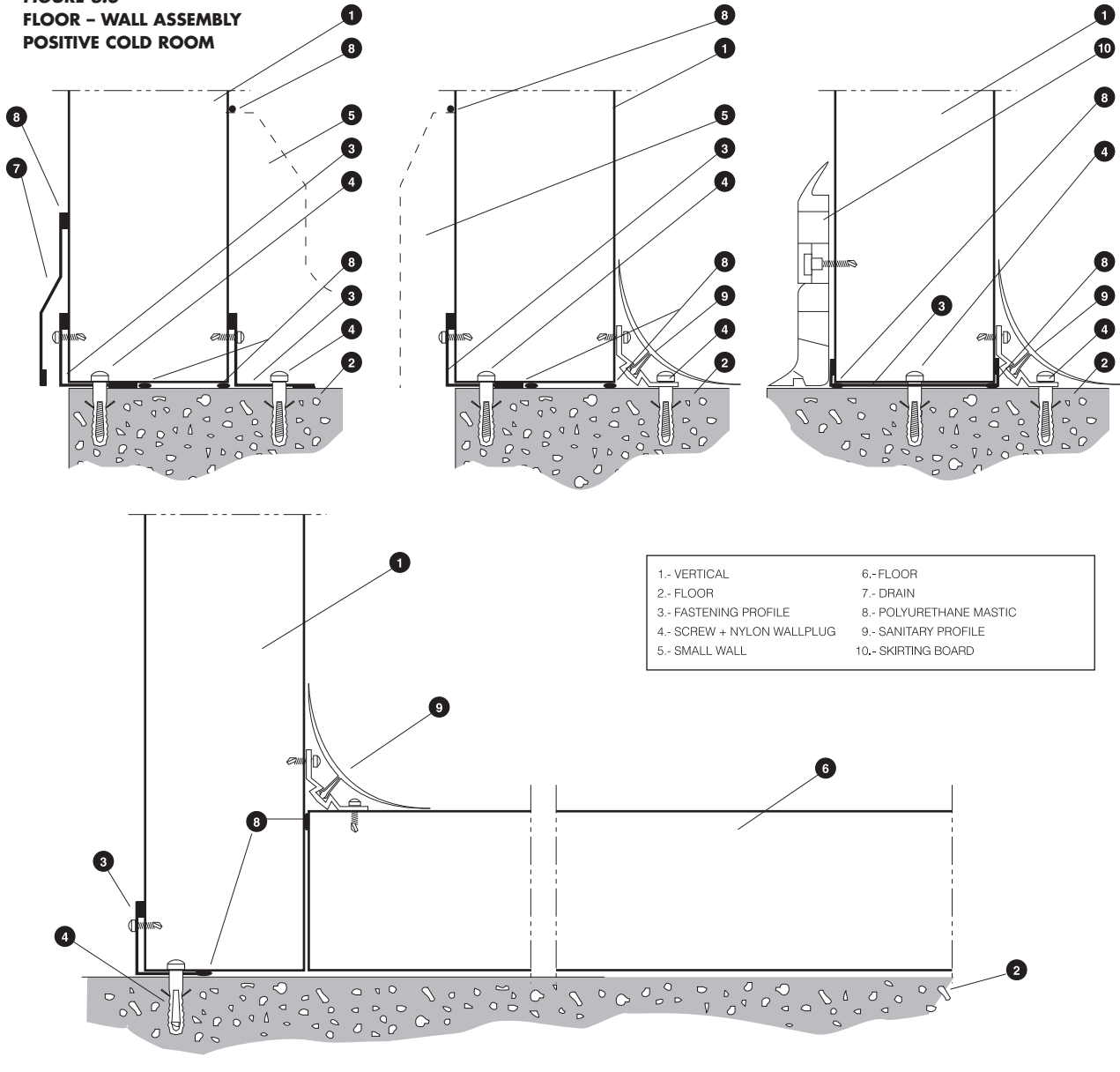
- Floor – Wall Assembly (Figure 6.6)
- Wall – Wall Assembly (Figure 6.7)
- Wall – Roof Assembly (Figure 6.8)

## 6.4 Floor preparation

In general terms and in all cases in the assembly of Cold Rooms, the floor should be totally levelled and smooth.

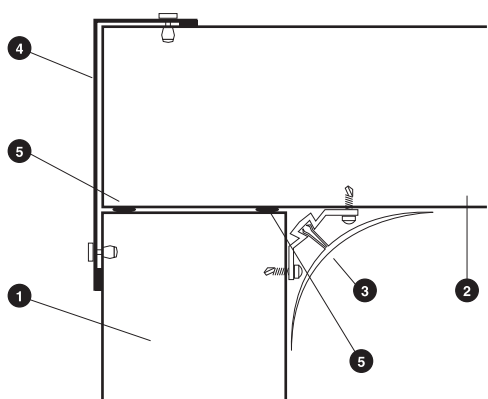
The way in which the Cold Room is going to be built and the use to which it will be put determines the different ways of preparing the floors for the assembly of the Cold Rooms.

**FIGURE 6.3**  
**FLOOR - WALL ASSEMBLY**  
**POSITIVE COLD ROOM**



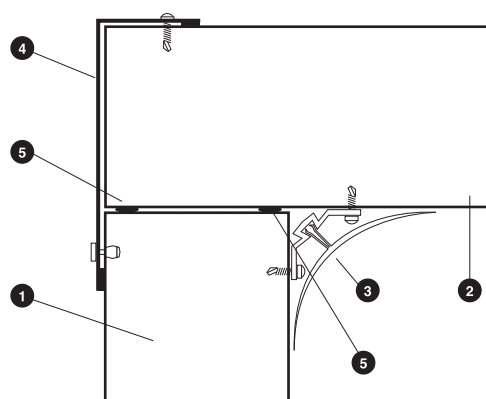
**FIGURE 6.4**  
**WALL - WALL ASSEMBLY**  
**POSITIVE COLD ROOM**

- 1.- VERTICAL
- 2.- VERTICAL
- 3.- SANITARY PROFILE
- 4.- EXT. ANGULAR PROFILE
- 5.- MASTIC SILICONE



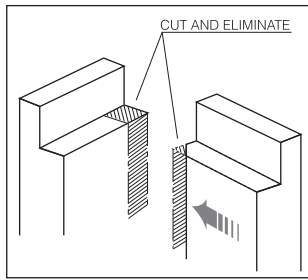
**FIGURE 6.5**  
**WALL - ROOF ASSEMBLY**  
**NEGATIVE COLD ROOM**

- 1.- VERTICAL
- 2.- ROOF
- 3.- SANITARY PROFILE
- 4.- EXT. ANGULAR PROFILE
- 5.- MASTIC SILICONE

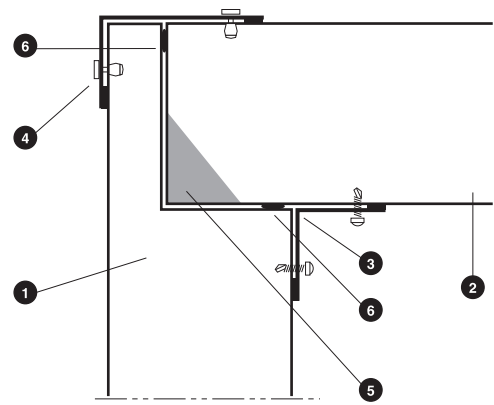




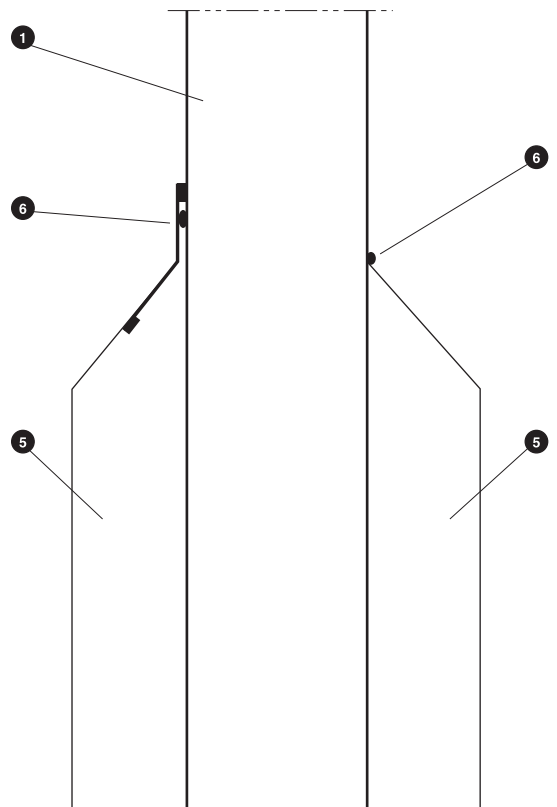
**FIGURE 6.7 WALL - WALL ASSEMBLY**



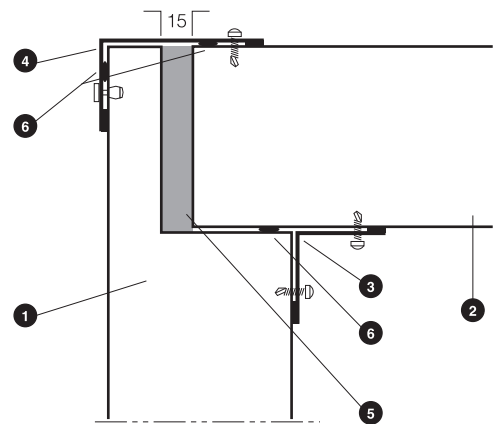
- 1.- VERTICAL
- 2.- VERTICAL
- 3.- INT. ANGULAR PROFILE (CH/0014)
- 4.- EXT. ANGULAR PROFILE (CH-0266)
- 5.- POLYURETHANE INJECTION
- 6.- POLYURETHANE MASTIC



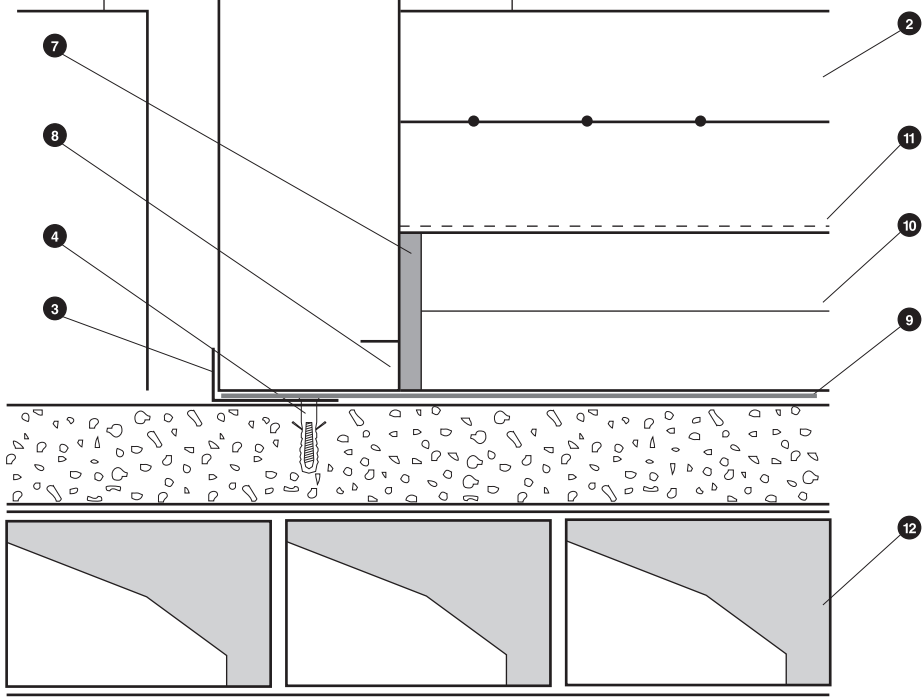
**FIGURE 6.6 FLOOR - WALL ASSEMBLY**



**FIGURE 6.8 WALL - ROOF ASSEMBLY**



- 1.- VERTICAL
- 2.- ROOF
- 3.- INT. ANGULAR PROFILE (CH/0014)
- 4.- EXT. ANGULAR PROFILE (CH-0266)
- 5.- POLYURETHANE INJECTION
- 6.- POLYURETHANE MASTIC



- 1.- VERTICAL
- 2.- CONCRETE
- 3.- FASTENING PROFILE (CH/0066)
- 4.- SCREW AND NYLON WALLPLUG
- 5.- SMALL WALL
- 6.- POLYURETHANE MASTIC
- 7.- POLYURETHANE INJECTION
- 8.- THERMAL BRIDGE BREAKING POINT
- 9.- WATER VAPOUR BARRIER
- 10.- FLOOR INSULATION
- 11.- IMPERMEABLE AGENT
- 12.- AIR COLLECTOR

# Technical Specifications

## 6.4.1 Refrigerating Chambers

### • Without floor insulation (more general use)

In this case, at the very least the perimeter where the vertical Panels will be placed should be completely levelled and smooth.

### • With insulating floor

In this case, it will be a hollow space, in which the floor insulation will be put, which has to be levelled and smoothened.

## 6.4.2 Freezing Chambers

The difference between these and the refrigerating chambers lies in the need to take precautions to avoid freezing the Chamber Floor.

The most usual ways of protecting the floor against freezing are:

- Channelling the air (natural or forced).
- Electric Resistance.
- Tubes with glycol water.

### 6.4.2.1 Preparation of the floor against freezing

#### A) Natural ventilation (Figure 6.9)

It is the system most recommended by KIDE. In this system air is circulated under the floor insulation thereby obtaining a temperature greater than 0°C and thus avoiding the freezing of the floor.

This ventilation will be from the vault or tube. In both cases, the vault or the tube will make it flow into 2 collectors which in turn will have an entrance and an outlet of air through chimneys of 2,5 and 0,5 m height respectively, which are the ones which make the air flow.

One of the collectors will have a connection to the general network for draining water which may be formed. It is convenient to have the conduit slightly inclined (minimum 2%) towards the drainage pipe.

Another variation is to avoid the chimney and install fans to force air circulation and in very cold areas to add electrical resistances controlled by thermostat which ensure that the air temperature never goes below 0°C.

#### B) Electrical Resistance

An electrical Resistance is installed below the insulation with a power of 10 to 20 W/m<sup>2</sup>.

It is convenient to install 2 sets of resistances (1 as a reserve), as it is installed under the ground. In case of a failure the reserve can be used.

#### C) Glycol Water

In the same way that the resistances are installed, some tubes are installed in which glycol water circulates. Also the water circulation is controlled thermostatically.

## 6.4.3 Chambers installed between 2 floor levels

In these cases, the lower level is considered as a vault (consider that the lower structure will be able to support the weight of the Chamber).

All the Chambers should have floor insulation.

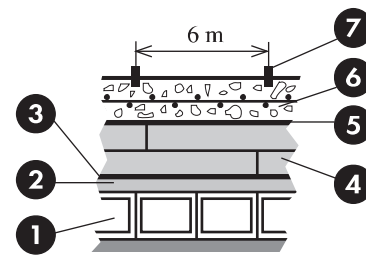
It is indispensable to install the vapour barrier before the insulation.

## 6.4.4 Floor Preparation. General Aspects

(Fig. 6.10)

- 1 -Hollow Vault or brick, tube, etc...
- 2 -Concrete filling.
- 3 -Vapour Barrier which will be a bituminous lamina (blade) hot-soldered with an armature of aluminium interior.
- 4 -Insulating plates interposed and stuck with bituminous adhesive (sealant) applied hot.

FIGURE 6.10



5 -Impermeable Agent which could be polyethylene of 0,2 mm with the objective of protecting against the permeation of water which the concrete may have.

6 -Reinforced Concrete with a characteristic resistance of 200 Kg/cm<sup>2</sup>, forming a layer of at least 120 mm thick. The armature will be of electrically soldered grating formed by rods of 5 mm diameter each 150 mm.

7 -The retracting seal should be of thickness between 5 and 10 mm and a depth of 1/3 of the thickness of the reinforced concrete forming a square of 6 m side.

In this kind of installation, the most important factor is the screen or anti-vapour barrier.

If this barrier is not correctly installed, there will be a flow of water vapour from the outside into the inside.

The vapour barrier ought to be continuous, in both smooth surfaces and in joints, and should be placed in such a way that although there may be movements, it will not break. The vapour barrier once installed should not leave any hollow space. It should be completely insulated.

## 6.5 Distances or Separation between top structures and mid-structures (peripheral)

The separation between reinforcement ties is determined as a function of the following criteria:

- Deflection limited to L/200
- Safety Coefficient of 2 for breakage and 1,5 for permanent deformation..
- Strength of the fastening elements.

The first two criteria are complied by using data from the graphs in Table 1 and Table 2, which give us the admissible distances as a function of the thickness and the load.

The strength of the fastening elements is given in Table 3.

## 6.6 Usual or Operating Overloads

### 6.6.1 Vertical Panels

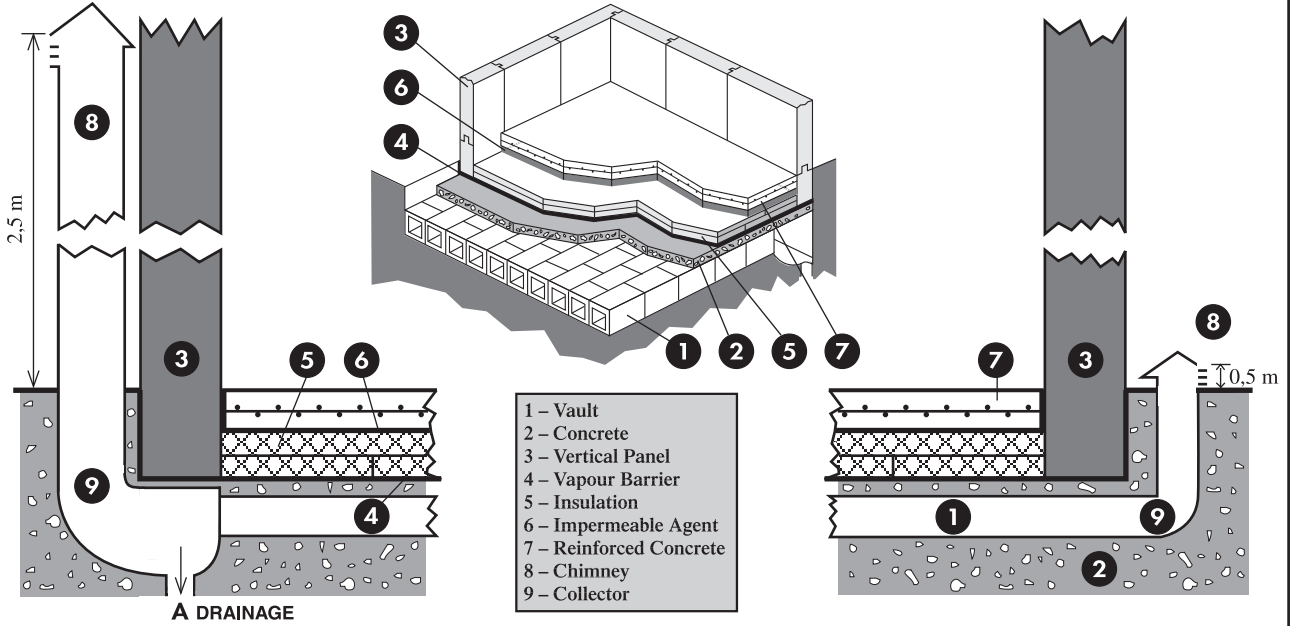
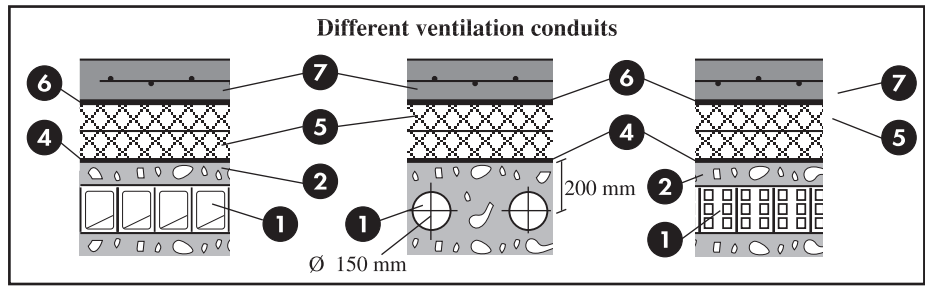
- Depression or Overpressure caused by the refrigerating installation working at 10 Kg/m<sup>2</sup> (equilibrium valves)
- Climatic Aspect (wind effects) according to Standards.
- Accidental Overload: 10 Kg/m<sup>2</sup>
- Thermal Load

### 6.6.2 Roof Panels

- Depression or Overpressure caused by the refrigerating installation working at 10 Kg/m<sup>2</sup> (equilibrium valves)
- Own weight of the Panel (Table 4)
- Thermal Load
- Safety Maintenance Load:
  - 10 Kg/m<sup>2</sup> (uniformly spread)
  - 150 Kg (at the point)

**Note:** The cold elements and other instalations, can not be fixed or hung from coldroom roof, but must have its own structure or being fixed to.

FIGURE 6.9



- 1 - Vault
- 2 - Concrete
- 3 - Vertical Panel
- 4 - Vapour Barrier
- 5 - Insulation
- 6 - Impermeable Agent
- 7 - Reinforced Concrete
- 8 - Chimney
- 9 - Collector

TABLE 1

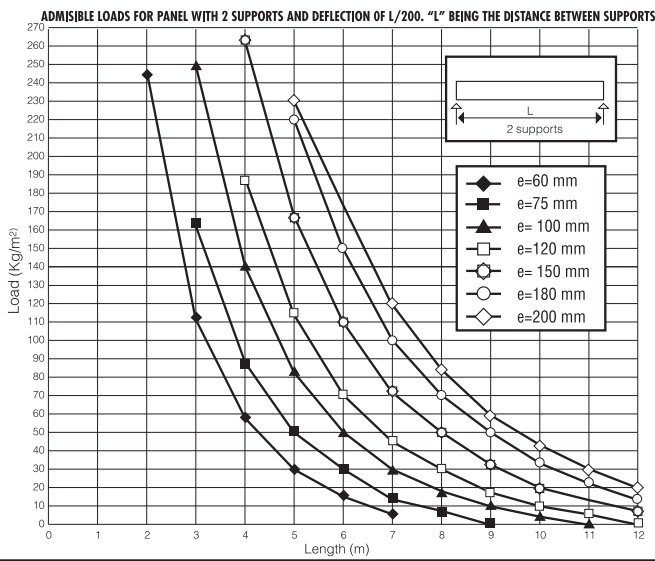


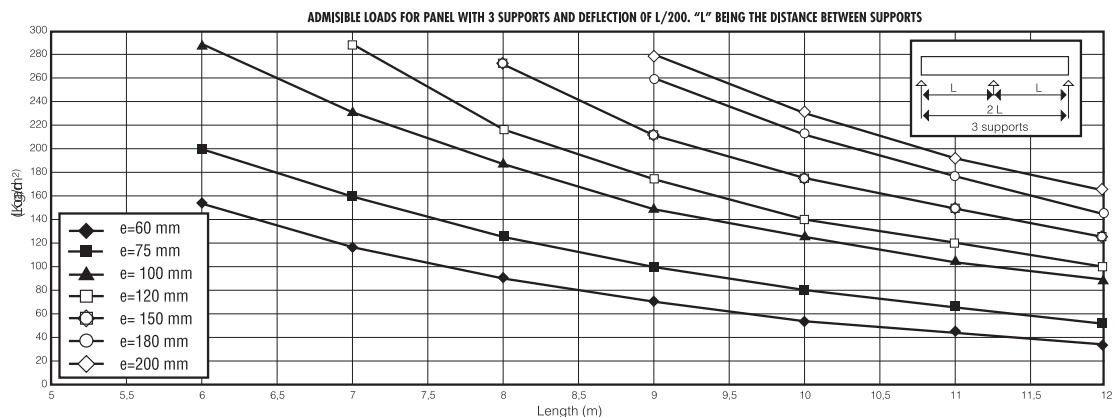
TABLE 3

	MAX.
FASTENING BETWEEN NYLON BOLT AND WASHER	150 KG
FASTENING BY INSERTION AT THE END	150 KG
FASTENING BY INSERTION IN THE MIDDLE OF PANEL	200 KG
ALUMINIUM PROFILE PER SPECIFIC FASTENING	500 KG

TABLE 4

PANEL THICKNESS	WEIGHT IN KG/M²
60	11
75	12
100	13
120	14
150	15
180	17
200	18

TABLE 2



## Technical Specifications

The roofs should not be used as areas for temporary or permanent storage.

The roofs are not areas for moving about. However, the occasional use by a person with a tool box is acceptable. The continuous use over the same area could provoke, due to elastic deformation of the panel, the removal of the foam and weaken the strength of the panel.

It is advisable to instal walkways for the repetitive moving around of the maintenance and assembling staff.

### 6.7 Maximum gaps in the Vertical Walls

#### 6.7.1 Open Building. Exterior Vertical Panels

Generally, the exterior vertical panels faced to be wind should fix on one or more peripheral edge rails.

Exceptionally, vertical panels that are inferior to 4 meters height (referring to any thickness).

The maximum distance between two edge rails or between the floor and the first edge rail must not exceed the following values.

The upper part of the vertical panel should be fix always on the structure. The higher edge rail should be situated minimum at 150 mm from the upper edge of the vertical panel and preferably between 0,5 and 1 meter from it.

PANEL THICKNESS	60	75	100	120	150	180	200
DISTANCE	3,5	4	4,5	5	5	5	5

#### 6.7.2 Closed Building

PANEL THICKNESS	60	75	100	120	150	180	200	TOTAL LOAD
REFRIG. TEMP. > 0°C	5,5	6,5	8	9	10			20 Kg/m <sup>2</sup>
FREEZER TEMP. ≤ -18°C			6	7	8	9	9,5	50 Kg/m <sup>2</sup>
DEEP FREEZER TEMP. = -35°C					7	8	8	70 Kg/m <sup>2</sup>

### 6.8 Maximum gaps in the self-supporting roofs

#### 6.8.1 Open Building. Exterior Vertical Panels. Roofs under cover.

PANEL THICKNESS	60	75	100	120	150	180	200	TOTAL LOAD
REFRIG. TEMP. > 0°C	4	5	6	7	8			50 Kg/m <sup>2</sup>
FREEZER TEMP. ≤ -18°C			5,5	6,5	7,5	8	8	60 Kg/m <sup>2</sup>
DEEP FREEZER TEMP. = -35°C					7	8	8	70 Kg/m <sup>2</sup>

#### 6.8.2 Closed Building

PANEL THICKNESS	60	75	100	120	150	180	200	TOTAL LOAD
REFRIG. TEMP. > 0°C	5	6	7	8				30 Kg/m <sup>2</sup>
FREEZER TEMP. ≤ -18°C			6	7	8	8	8	50 Kg/m <sup>2</sup>
DEEP FREEZER TEMP. = -35°C					7,5	8	8	60 Kg/m <sup>2</sup>

### 6.9 Number of tensors

Due to assembly reasons, when fastening is made by aluminium profiles which support the roof panels, the maximum distance between the tensors must be of 1200 mm, and a maximum eave of 500 mm\*.

When fastening is made by washers or insertions, minimum 2 tensors or each panel should be used.

\* Valid for a maximum load of 60 dN/m<sup>2</sup> (maximum length of 5 m. for E = 60 and 6 m. for the rest), with a security rate of 2 and a maximum deflection of L/200.

For bigger loads and longer panels, contact us.

## 7 Packing. Maintenance

### 7.1 Panel Labelling

A label is placed on each panel which shows:

- The type of the panel.
- The order number which assures its traceability.

### 7.2 Accessories

#### • Standard Packing

The panels, together with the doors, are stacked to form a compact package. The whole package is wrapped in a plastic protective sheet.

#### • Sea-worthy Packing

The panels are stacked in the same way as above, but are introduced into complete wooden cases, built according to international standards.

### 7.3 Points of Consideration

- Stacking the panels in a horizontal manner in the original pallet.
- Never stack on unlevelled or humid floor where flooding is possible.
- Store the panels preferably in a dry place, protected against humidity and heat.
- If the panels have to be stored outdoors, protect the panels with wool or plastic allowing air flow.
- The storing conditions may alter the transparent plastic protection of the Panels and make its removal difficult. The time for removing this protective sheet is:
  - 15 days for storage under the sun and outdoors without protection.
  - 2 months for storage outdoors but covered by opaque canvas.
  - 6 months for storage protected against heat and humidity.

### 7.4 Maintenance

The estatement and tension of the ceiling fastening must be checked, as well as the cleaning of the ceiling panels, every six months at least.

Panel sheets should be washed with running water and neutral agent, followed by rinsing with running water and dried.

Repairs: The original coat can serve as a primary one, cleaning with running water with an active detergent, rinsed well and dried, followed by slight sand-papering and powder removal, before giving it a new coat.

In order not to lower the quality of the coat with cleaning agents, it is advisable:

- To respect the dose (frequently from 1 to 3% and the PH value between 5 and 9)
- To dilute in warm water (around 20°C, but always below 40°C)
- To respect the application temperature (ideal 30°C, up to a **maximum of 50°C** to eliminate fats)
- To respect the pressures of application (**máximum 50 bars**)
- Not to go over the application time (**máximum 30 min.**)
- To clear up with abundant clear water (maximum pressure 50 bars at a temperature of less than 30°C)
- The areas with a temperature lower than or equal to 0°C should be cleaned with a lot of water.

For persistent stains, rub with a sponge which has been soaked in the appropriate cleaning agent, without modifying the aspect of the finish, and clear up rapidly with abundant clear water.

**KIDE RESERVES THE RIGHT TO MODIFY THIS DOCUMENT WITHOUT PREVIOUS WARNING**